



M 200 H

EL VEHICULO MULTIUSOS QUE FACILITA TU TRABAJO
THE TOOL-CARRIER THAT MAKES YOUR WORK EASIER
MULTISERVICE DAS VIELSEITIGE FAHRZEUG FÜR DIE KOMMUNE UND DEN DIENSTLEISTER
LE VEHICULE MULTISERVICE QUI FACILITE VOTRE TRAVAIL



M 200 H

AUSA
www.ausa.com

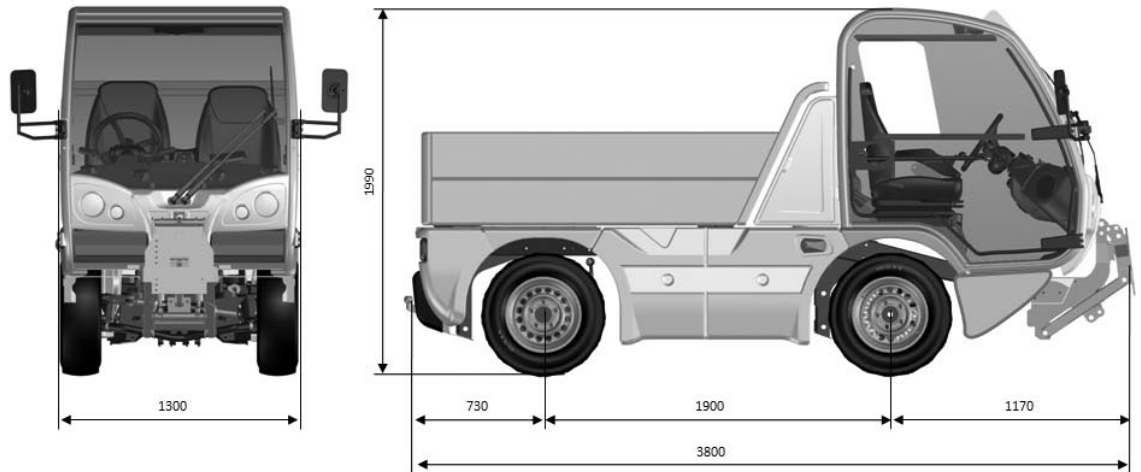

TECHNICAL SPECIFICATIONS

		M 200 H 4x2x2	M 200 H 4x2x4	M 200 H 4x4x4
Weight	Load Capacity	2500 Kg	2500 Kg	2500 Kg
	Unloaded weight	2300 Kg	2350 Kg	2400 Kg
	Max. Laden mass	5000 Kg	5000 Kg	5000 Kg
Maneuverability	External turning radius	3623 mm	2762 mm	2762 mm
Engine	Make	VOLKSWAGEN		
	Type	2.0 TDI Euro 5		
	Emissions	Euro 5		
	Power (Kw -HP)	75 -102 (3000 rpm)		
	N. Of Cylinders	4		
	Cooling system	Liquid with variable speed fan and auto cleaning system		
	Fuel	Diesel		
	Tank capacity	60 l		
Transmission	Type	Hydrostatic Rexroth with 2 wheel radial motors on rear axle		Hydrostatic Rexroth with 2 wheel radial motors on each axle
	Max speed	40 km/h		
	Max working speed	25 km/h		
	Gradient negotiable	27% at full load (30% at 4500 Kg)		
Brakes	Service	Servo assisted brake, disk brake on front wheels and drum brakes on rear wheels		Servo assisted brake. Drum brakes on rear wheels
	Parking	Mechanical brake on rear axle		
Steering	Type	Orbitrol hydraulic steering		
	Modes	Front	Front / Front + Rear	Front / Front + Rear
Suspension	Front	Hydraulic absorbers + Springs		
	Rear	Hydraulic absorbers , Springs and anti roll bar		
Wheels	Front / Rear	225/75 R16		
Auxiliary hydraulic circuit	Hydraulic Pump	Triple gear pump - 22cc - 16cc - 11cc		
	Front Quick Couplings	3 quick-attach and independent hydraulic couplings (5 l/min) and 1 quick-attach hydraulic coupling (50 l/min)		
	Rear Quick Couplings	1 quick-attach and independent hydraulic couplings (5 l/min) - 1 quick-attach and independent hydraulic couplings (20 l/min) - 1 quick-attach and independent hydraulic couplings (50 l/min)		
Cargo Box	Dimensions	1790 x 1260 x 420		
STANDARD EQUIPEMENT	Front plate tool-carrier Link® System			
	Driver position on the left side of the vehicle			
	Driver seat with mechanical suspension			
	Passenger seat without suspension			
	Steering wheel with regulation on height and depth			
	High capacity heater			
	Electronic control for the speed of the engine			
	Electronic control for the speed of the vehicle			
	Radio pre installation			
	Quick coupling Link® system			
	AUSA fuel saving system (A.F.S.) in long distance travel at high speed			
	Front plate tool-carrier Link® System - Triangular coupling bracket			
	Right hand drive			
	Driver seat with pneumatic suspension			
Electrically adjustable rear mirrors with heater				
Working lights on the top of cabin LED				
Automatic grease system				
Air conditioning				
Radio stereo equipment				
Radio/CD stereo equipment				
Towing hitch (50 mm ball & 13 pins) with electric socket				
Capacity 750 kg without brake; 3.500 kg with brake				
Extensible legs for cargo box disassembly				
Camera rear vision with display in cabin				
OPTIONAL EQUIPEMENT				

MKT22035.01/04.2012

AUSA reserves the right to make any changes in the specifications without prior notice.