



We build a better future

■ Photo may include optional equipment

HYUNDAI DIESEL FORKLIFT TRUCKS - Applied Tier 3 Engine

# 250D-7E



# NEW criterion of Big Forklift Truck

Hyundai introduces a new line of 7E-series diesel forklift trucks. Excellent power and performance make your business more profitable.





## Excellent



Cruise control



Switch panel



Air conditioning & heater



Rear view camera



Load Indicator



ESL (Engine Start Limit)

■ Photo may include optional equipment

# The new master on your job-site!

Smooth running, efficient and ergonomically designed, 250D-7E series are made to meet your needs.



## Powerful Engine Cummins QSC Engine

The six cylinders turbo-charged engine is built for power, reliability and economy. This engine meets EPA Tier 3 and EU stage IIIA emission regulation.



### Engine control mode

According to the application, the operator can select the preferable engine mode with a single switch.

STANDARD Mode : Fuel efficient mode for light applications

POWER Mode : Full power mode for heavy-duty applications



### Adjustable engine idling RPM

With engine running, idling rpm can be adjusted by units of 25rpm, this preset is saved automatically.

**194 kW / 2,200 rpm**  
**120.4 N.m / 1,400 rpm**

## Full-automatic transmission

The Full-automatic transmission offers easy and convenient handling with soft, smooth shifting. The operator can select two types of automatic modes. (1st↔3rd, 2nd↔3rd)



### Cruise control

Maintain automatically a desired engine speed with no accelerator pedal input in order to reduce fuel consumption and operator fatigue.



### Transmission control switch



### Excellent night work

- Various positions of work lamps provide the operator with better visibility, higher level of comfort and safer operation.
- Front working lamps: 2 pc. on fender, 2pc. on mast(2)
- Rear working lamps: 2 pc. on cab



# High Power Low Noise



■ Photo may include optional equipment



### Increased mast tilting angle

Utilizing the mast tilting angle of 12 degrees forward and 10 degrees backward, the operator can perform (un)loading jobs safe and rapidly.

### Faster travel speed & better grade-ability

The powerful engine provides great acceleration, high grade-ability and fast travel speed on tough terrain or slopes.



### Grade-ability (Loaded)

**250D-7E : 33.8 %**

### Travel speed (Unloaded)

**250D-7E : 31.7 km/h**

# Comfortable operation!

A design based on human engineering relieves fatigue and increases operator's efficiency.

## Operator friendly gauges and water-resistant monitor panel



## Easily adjustable suspension seat

An attractive and adjustable seat, based on human engineering design, provides great comfort, safety and durability. (Head rest - option)



## High-capacity air conditioner & heater (Option)

An integrated air conditioner and heater saves space inside the cabin. With its high capacity, the operator is, both in summer and winter, able to create a pleasant operating environment.



## Rear view camera

The rear view camera makes the operation more easy and convenient. And it supports 4 camera channels.



## Load Indicator



## Concentrated switch panel



## MP3 / CD Player with remote control



## Hands free socket (Option)



■ Photo may include optional equipment



### Quick response of hydraulic levers

Only minimal operator's effort is required for precise, safe and productive control.  
(3-Levers : standard // 4 or 5-Levers : option)



### Ergonomical positioned pedals

Based on human engineering, the accelerator, brake and inching pedals are optimally positioned for operator's convenience.



### Adjustable steering column

Steering column can be adjusted depending on the operator's preferences to create a comfortable operating environment.



# Safety through high durability!

Safety and durability are priorities in design of our equipment.



## Hydraulic driven cooling system

The minimum fuel consumption and low noise are available by applying hydraulic cooling fan sensing intake air temperature, transmission oil temperature, coolant temperature and hydraulic temperature.

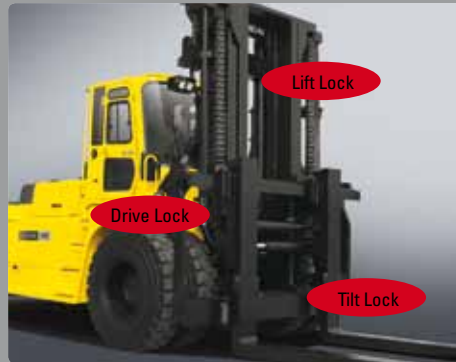

## OPSS (Operator Presence Sensing System)

Mast tilting, lifting and lowering operation is not possible when the operator is not seated in the normal position.

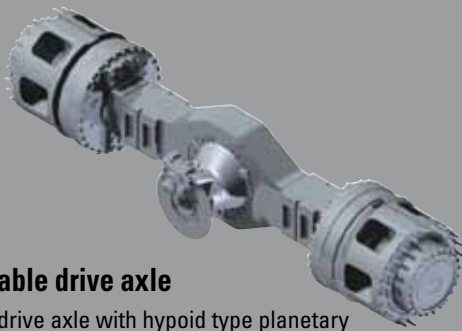

## Durable drive axle

The drive axle with hypoid type planetary reduction smoothly delivers the desired torque to the drive wheels.



## Auto parking

The parking brake is engaged automatically when the transmission is in neutral position and the operator leaves the seat.



## Wet disc brake system

Wet disc brakes improve the brake performance and make your service intervals longer. Enclosed brakes are protected against dust and water.



## Protector for hub bolts

By applying protector for preventing bolts breakage durability has been improved. (Same size of front and rear wheels)



## Cabin Tilting automatic system

Cabin tilting electronic system makes servicing of all power train components quick and easy. An electrically assisted hydraulic actuated cylinder tilts operator cabin to left side about 65 degrees for easy access to inside of truck components.



## Grease fittings

Grease fittings are installed for easy access to steering axle center pin when doing service checks.





■ Photo may include optional equipment



**Durable mast & carriage side rollers**

Side rollers with great durability for mast and carriage are used.



**Reliable fork carriage**

The fork carriage of high tensile structural steel has an excellent durability and is very reliable.



**Large footboard & handle**

Wide "open" step offers convenience and safety when entering and exiting your truck.

# Centralized design for easy service!

An ideal arrangement of components ensures easy access and convenience for maintenance.



## Large engine hood

Highly accessible engine compartment assures fast and efficient maintenance.



## Easy change of air cleaner

This air filter is readily accessible for cleaning or replacement.



## Cabin air fresh filter

To exclude dust and to reduce noise levels there's a low overpressure maintained inside the cabin.



## Compact fuse box for easy inspection



## Mechanic Friendly Fuel Filter Replacement

Highly accessible engine compartment allows for quick replacement of filters.



## Electrically monitored air filter

Air cleaner sensor alerts the operator of a clogged air filter and allows replacement before damage.



## Automatic locking gas spring

Engine compartment hood is safely kept open by a self locking gas spring.



■ Photo may include optional equipment



### Master switch

A master switch disconnects the battery power to protect the electrical system from electrical drainage.



### Large tool box



### Pressure gauge port



### Easy engine oil check

## Mast specifications

Mast Type	Maximum Fork Height (mm)	Overall Height Lowered (mm)	Tilt Angle (deg)		Load Capacity 1,200 mm LC (kg)	Truck Weight Unloaded (kg)	
			Fwd	Bwd			
250D-7E							
2-Stage Limited Free Lift	* V400	4,030	3,877	12	10	25,000	37,021
	V450	4,530	4,127	12	10	25,000	37,271
	V500	5,030	4,377	12	10	25,000	37,526
	V550	5,530	4,627	12	10	24,950	37,788
	V600	6,030	4,877	12	10	24,950	38,379
	V650	6,530	5,127	12	10	24,450	38,686
	V700	7,030	5,377	12	10	23,550	38,968

## Load capacity

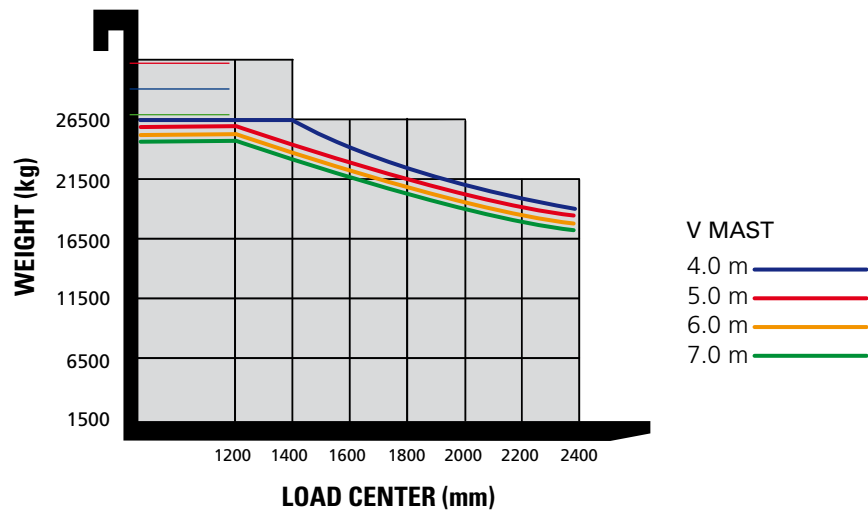

## Optional Items

- **FORKS: (L x W x T) (mm)**  
 2,450 x 250 x 110(STD)  
 3,150 x 250 x 110  
 3,650 x 250 x 110
- **MCV: 6 - SPOOL**
- **FORK POSITIONER**
- **INTEGRATED FORK POSITIONER(INDEPENDENT) + SIDE SHIFT(STD)**
- **INTEGRAL FORK POSITIONER + SIDE SHIFT**
- **AIR COMPRESSOR**
- **HANDS FREE**
- **TERMINAL WEST FORK CARRIAGE**
- **BEACON LAMP**

## Dimensions

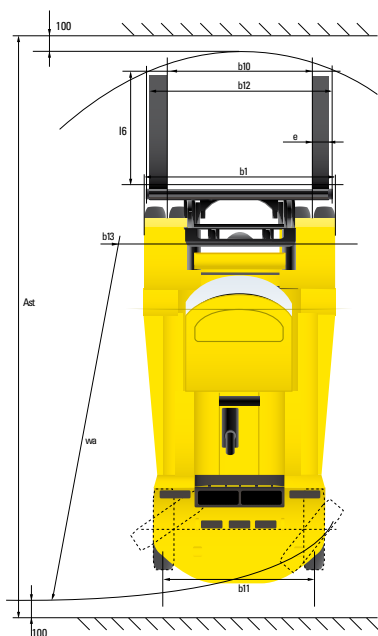
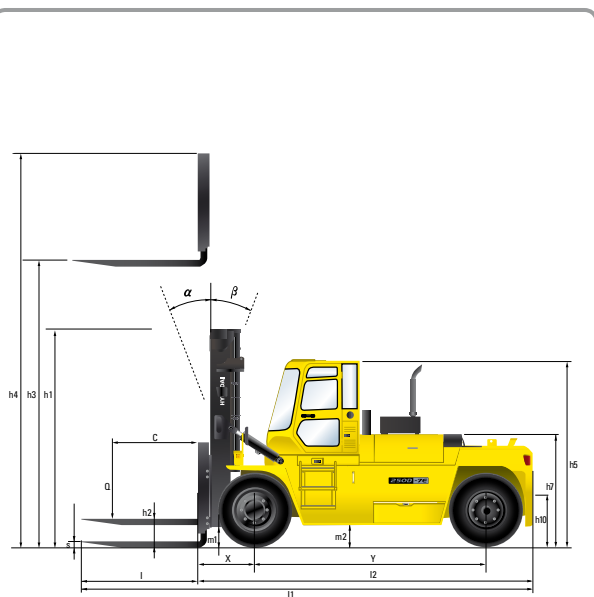

## Specifications

Identification		
1.1	Manufacturer	Hyundai
1.2	Type	250D-7E
1.3	Drive: electric (battery or mains), diesel, petrol, fuel gas, manual	DIESEL
1.4	Type of operation: hand, pedestrian, standing, seated, order-picker	seated
1.5	Load capacity (standard)	Q (t) 25.0
1.6	Load center distance	c (mm) 1,200
1.8	Load distance, center of drive axle to forks	x (mm) 1,112
1.9	Wheelbase	y (mm) 4,300
Weights		
2.1	Service weight	kg 37,021
2.2	Axle loading, loaded front/rear	kg 57,277 / 41,744
2.3	Axle loading, unloaded front/rear	kg 18,647 / 18,374
Wheels, chassis		
3.1	Tires: solid rubber, superelastic, pneumatic, polyurethane	Pneumatic
3.2	Tires size, front	14.00 - 24 - 28PR
3.3	Tires size, rear	14.00 - 24 - 28PR
3.5	Wheels, number front / rear (X= driven wheels)	4 x 2
3.6	Track width, front	b10 (mm) 2,212
3.7	Track width, rear	b11 (mm) 2,140
Basic dimensions		
4.1	Mast/fork carriage tilt forward/backward	degrees 12 / 10
4.2	Lowered mast height (standard)	h1 (mm) 3,877
4.3	Free lift	h2 (mm) 0
4.4	Lift height (standard)	h3 (mm) 4,030
4.5	Extended mast height (standard)	h4 (mm) 5,837
4.7	Overhead load guard (cab) height	h5 (mm) 3,223
4.8	Seat height / standing height	h7 (mm) 2,150
4.12	Coupling height	h10 (mm) 528
4.19	Overall length	l1 (mm) 8,812
4.20	Length to face of forks	l2 (mm) 6,362
4.21	Overall width	b1 (mm) 3,050
4.22	Fork dimensions LxWxT	L x E x S (mm) 2,450 x 250 x 110
4.24	Fork carriage width	b12 (mm) 2,600
4.31	Ground clearance, loaded, under mast	m1 (mm) 300
4.32	Ground clearance, centre of wheelbase	m2 (mm) 250
4.33	Aisle width for pallets 1000 x 1200 crossways (L x W)	Ast (mm) 9,569
4.34	Aisle width for pallets 800 x 1200 lengthways (W x L)	Ast (mm) 9,569
4.35	Turning radius	Wa (mm) 5,807
4.36	Smallest pivot point distance	b13 (mm) 1,981
Performance data		
5.1	Travel speed, unloaded	km/h 31.7
5.2	Lift speed, loaded/unloaded	m/s 250 / 280
5.3	Lowering speed, loaded/unloaded	m/s 400 / 300
5.5	Drawbar pull, loaded	N 21.5
5.7	Gradient performance, loaded/unloaded	% 33.8
5.10	Service brake	Wet, Hydraulic
Engine		
6.1	Engine manufacturer / type	Cummins QSC
6.2	Engine power acc. To ISO 1585	kW 194
6.3	Rated speed	1/min 2200
6.4	No. of cylinder / cubic capacity	/cm <sup>3</sup> 8,300
6.5	Fuel consumption acc. to VDI cycle	ℓ/h 25
Other details		
8.1	Type of drive control	Power Shift
8.2	Operating pressure (attachments)	bar 240 / 160
8.3	Hydraulic oil flow (attachments)	ℓ/min 270
8.5	Sound level at driver's ear according to DIN 12053	db(A) 77



**Notes**

Lined area for taking notes, consisting of numerous horizontal dotted lines.

**Notes**

A series of horizontal dotted lines for writing notes.



*PLEASE CONTACT*