

Dimension

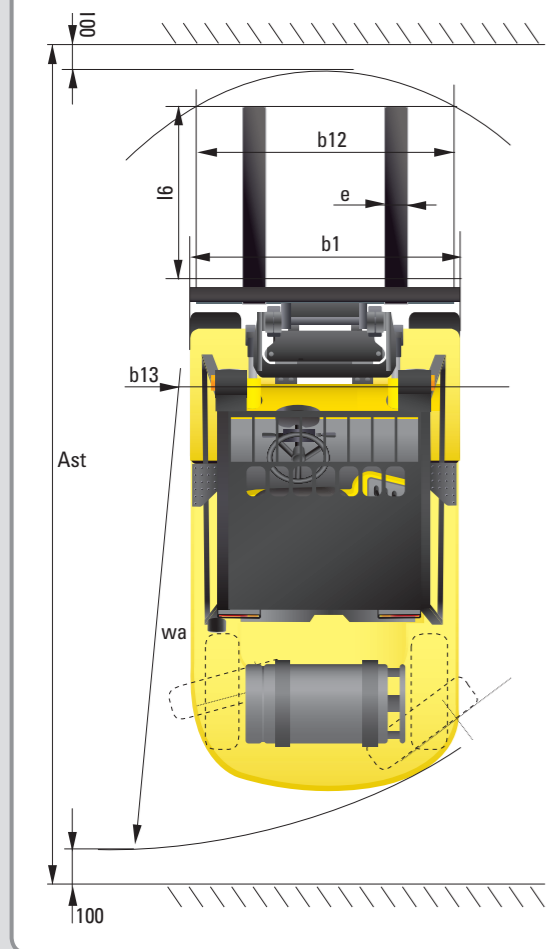

Specification

| Identification | | | | | | |
|------------------|--|--------------------------|--------------------------|--------------------------|--------------------------|------------------|
| 1.1 | Manufacturer | Hyundai | Hyundai | Hyundai | Hyundai | |
| 1.2 | Manufacturer's type designation | 35L-7A | 40L-7A | 45L-7A | 50L-7A | |
| 1.3 | Drive: electric (battery or mains), diesel, petrol, fuel gas, manual | LP | LP | LP | LP | |
| 1.4 | Type of operation: hand, pedestrian, standing, seated, order-picker | seated | seated | seated | seated | |
| 1.5 | Load capacity / rated load | Q (kg) | 3,500 | 4,000 | 4,500 | 5,000 |
| 1.6 | Load center distance | c (mm) | 600 | 600 | 600 | 600 |
| 1.8 | Load distance, center of drive axle to fork | x (mm) | 561 | 561 | 561 | 576 |
| 1.9 | Wheelbase | y (mm) | 2,000 | 2,000 | 2,000 | 2,000 |
| Weights | | | | | | |
| 2.1 | Service weight | kg | 5,748 | 6,163 | 6,579 | 7,043 |
| 2.2 | Axle loading, loaded front/rear | kg | 8,330/918 | 9,094/1,069 | 9,891/1,188 | 9,926/1,617 |
| 2.3 | Axle loading, unloaded front/rear | kg | 2,798/2,950 | 2,772/3,391 | 2,779/3,800 | 2,814/4,229 |
| Wheels, Chassis | | | | | | |
| 3.1 | Tires: solid rubber, superplastic, pneumatic, polyurethane | Pneumatic / Solid rubber | Pneumatic / Solid rubber | Pneumatic / Solid rubber | Pneumatic / Solid rubber | |
| 3.2 | Tires size, front (width x Φ) | 8.25 x 15 x 14pr | 7.50 x 16 x 12pr | 7.50 x 16 x 12pr | 7.50 x 16 x 12pr | |
| 3.3 | Tires size, rear (width x Φ) | 7.00 x 12 x 12pr | 7.00 x 12 x 12pr | 7.00 x 12 x 12pr | 7.00 x 12 x 14pr | |
| 3.5 | Wheels, number front x rear (x=driven wheels) | 2x2 | 4x2 | 4x2 | 4x2 | |
| 3.6 | Track width, front | b10 (mm) | 1,132 | 1,282 | 1,282 | |
| 3.7 | Track width, rear | b11 (mm) | 1,140 | 1,140 | 1,140 | |
| Basic Dimensions | | | | | | |
| 4.1 | Mast/fork carriage tilt forward/backward (α / β) | degrees | 8/10 | 8/10 | 8/10 | 8/10 |
| 4.2 | Lowered mast height | h1 (mm) | 2,235 | 2,220 | 2,220 | 2,220 |
| 4.3 | Free lift | h2 (mm) | 120 | 120 | 120 | 120 |
| 4.4 | Lift height | h3 (mm) | 3,020 | 3,020 | 3,020 | 2,930 |
| 4.5 | Extended mast height | h4 (mm) | 4,224 | 4,224 | 4,225 | 4,147 |
| 4.7 | Overhead load guard (cab) height | h5 (mm) | 2,240 | 2,240 | 2,240 | 2,240 |
| 4.8 | Seat height/standing height | h7 (mm) | 1,100 | 1,100 | 1,100 | 1,100 |
| 4.12 | Coupling height | h10 (mm) | 385 | 385 | 385 | 385 |
| 4.19 | Overall length | l1 (mm) | 4,145 | 4,205 | 4,405 | 4,435 |
| 4.20 | Length to face of forks | l2 (mm) | 3,075 | 3,135 | 3,185 | 3,235 |
| 4.21 | Overall width | b1 (mm) | 1,370 | 1,746 | 1,746 | 1,746 |
| 4.22 | Fork dimensions | s / e / l (mm) | 50 x 122 x 1,070 | 50 x 150 x 1,070 | 50 x 150 x 1,220 | 50 x 150 x 1,200 |
| 4.23 | Fork carriage ISO 2328, class / type AB | | III / A | III / A | IV / A | IV / A |
| 4.24 | Fork-carriage width | b12 (mm) | 1,300 | 1,600 | 1,600 | 1,600 |
| 4.31 | Ground clearance, loaded, under mast | m1 (mm) | 170 | 155 | 155 | 155 |
| 4.32 | Ground clearance, centre of wheelbase | m2 (mm) | 200 | 200 | 200 | 200 |
| 4.33 | Aisle width for pallets 1000x1200 crossways | Ast (mm) | 4,567 | 4,620 | 4,666 | 4,708 |
| 4.34 | Aisle width for pallets 800x1200 lengthways | Ast (mm) | 4,767 | 4,820 | 4,866 | 4,908 |
| 4.35 | Turning radius | Wa (mm) | 2,806 | 2,859 | 2,905 | 2,947 |
| 4.36 | Smallest pivot point distance | b13 (mm) | 1,009 | 1,009 | 1,009 | 1,009 |
| Performance Data | | | | | | |
| 5.1 | Travel speed, Unloaded | km/h | 23.8 | 22.9 | 22.9 | 22.8 |
| 5.2 | Lift speed, Loaded/Unloaded | mm/s | 510/530 | 510/530 | 510/530 | 440/460 |
| 5.3 | Lowering speed, Loaded/Unloaded | mm/s | 500/450 | 500/450 | 500/450 | 500/450 |
| 5.5 | Drawbar pull, Loaded | kg | 4,002 | 4,065 | 3,930 | 3,911 |
| 5.7 | Gradient performance, Loaded | % | 40.5 | 36.2 | 31.6 | 28.7 |
| 5.10 | Service brake | | Hydraulic | Hydraulic | Hydraulic | Hydraulic |
| Engine | | | | | | |
| 6.1 | Engine manufacturer / type | | GM 4.3L | GM 4.3L | GM 4.3L | GM 4.3L |
| 6.2 | Engine power acc. to ISO 1585 | Kw | 70 | 70 | 70 | 70 |
| 6.3 | Rated speed | 1/min | 2,300 | 2,300 | 2,300 | 2,300 |
| 6.4 | No. of cylinder / cubic capacity | /cm ³ | 6/4,294 | 6/4,294 | 6/4,294 | 6/4,294 |
| Other Details | | | | | | |
| 8.2 | Type of drive control | | Power Shift | Power Shift | Power Shift | Power Shift |
| 8.3 | Operating pressure | bar | 225/168 | 225/168 | 225/168 | 225/168 |
| 8.4 | Oil volume | l/min | 30 | 30 | 30 | 30 |
| 8.5 | Noise | db(A) | 80 | 80 | 80 | 80 |

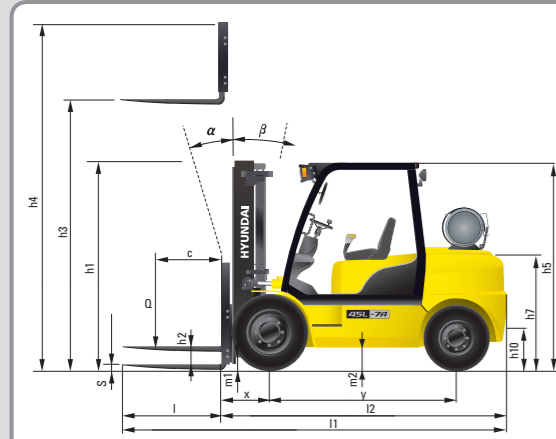

Some of the photos may include optional equipment.

HYUNDAI LPG FORKLIFT TRUCKS Applied Tier 4 Engine

35L/40L/45L/50L-7A

HYUNDAI FORKLIFT
HEAVY INDUSTRIES CO.,LTD.

Head Office(Sales Office)
14th FL., HYUNDAI BLDG. 140-2, KYE-DONG, JONGNO-GU, SEOUL, KOREA 110-793
Tel (82) (2) 746-4526, 4529 Fax (82) (2) 746-7444-7445

Americas Operation : Hyundai Construction Equipment Americas, Inc.
955 ESTES AVENUE, ELK GROVE VILLAGE IL, 60007 Tel (1) 847-437-3333 Fax (1) 847-437-3574

Europe Operation : Hyundai Heavy Industries Europe N.V.
VOSSENDAAL 11, 2440 GEEL, BELGIUM Tel (32) 14-56-2200 Fax (32) 14-59-3405

PLEASE CONTACT

www.hyundai-ce.com

2010.09 Rev.0.

HYUNDAI
HEAVY INDUSTRIES CO.,LTD.

We build a better future

NEW criteria of Forklift Trucks

Hyundai introduces a new line of 7A series LPG forklift trucks. Excellent power and performance make your business more profitable.



OPSS (Operator Presence Sensing System)
Control of mast tilting, lifting and lowering is not possible through operation of the appropriate control when the operator is not in the seated position.

■ Some of the photos may include optional equipment.

The new master on the job-site!

Smooth running, efficient and ergonomically designed, 35/40/45/50L-7A series are made to meet your needs.

70Kw/2,300rpm



Powerful Engine GM 4.3L V6 Engine

Market approved quality of GM 4.3L V6 engine ensures incomparable performance, durability and additional value to the machine. Powerful and efficient engine provides excellent fuel economy and excellent torque for improved operation.
(EPA/CARB Tier-IV Certified)

Fast and Stable Performance

Being able to quickly raise and lower the mast, as well as tilt it forward and backward, provides the best operational conditions during unloading.

When the truck is fully loaded, mast lowering speed is carefully controlled to ensure safety by the down control valve.

Mast(Lift and Tilt) Look System is standard.



Some of the photos may include optional equipment.

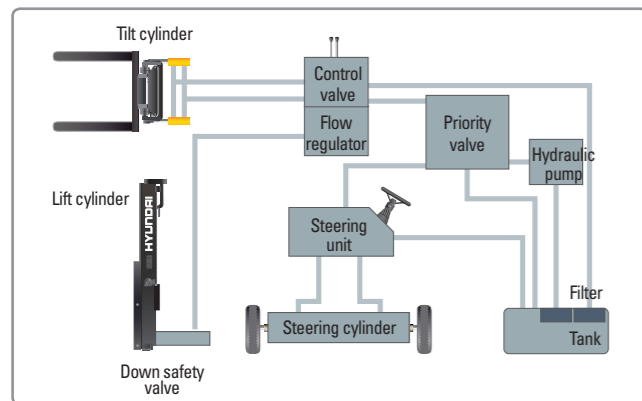

State-of-the-art Hydraulic System

The latest large-capacity hydraulic system reacts quickly during operation, and a low-noise control valve increases both efficiency and durability.



Fully Hydrostatic Power Steering

A hydraulic steering system always guarantees smooth and flexible steering, preventing overrun and kick-back.



Increased Mast Tilting Angle

Utilizing the mast tilting angle of 8 degrees forward and 10 degrees backward, the operator can safely and rapidly perform loading and unloading jobs.

Faster Travel Speed & Better Gradability

The powerful high-output engine provides greater acceleration, better gradability and faster travel speed on any tough terrains or slopes.



Gradability(Loaded)

35L-7A : 40.5% 45L-7A : 31.6%
40L-7A : 36.2% 50L-7A : 28.7%

Travel Speed(Unloaded)

35L-7A : 23.8 km/h
40L-7A : 22.9 km/h
45L-7A : 22.9 km/h
50L-7A : 22.8 km/h

Ergonomic operator friendly compartment design!

A design based on human engineering relieves fatigue and increases operator's efficiency.

Operator Friendly Gauges and Water-resistant Monitor Panel



- ① Parking brake lamp
- ② Turn lamp
- ③ Engine oil warning lamp
- ④ Transmission oil temperature warning lamp
- ⑤ Battery charging warning lamp
- ⑥ Air cleaner filter warning light
- ⑦ Working light indicator
- ⑧ Seat belt warning
- ⑨ Water temperature gauge
- ⑩ OPS warning (option)
- ⑪ Hour meter
- ⑫ Engine check lamp



Full Suspension Seat

An attractive and adjustable seat, based on a human engineering design, provides great comfort, safety and durability.



New High Visibility for Safe Operation

The operator is able to work with increased safety and accuracy due to a wider view mast.



■ Some of the photos may include optional equipment.



Ergonomically Positioned Pedals

Based on human engineering, the accelerator, brake and inching pedals are optimally positioned for convenience while operating the equipment.



Cup Holder & Console Box

Additional storage spaces are located inside the operating space for operator's convenience.



Quick Response of Operating Control Levers

Only minimal operator's effort is required for precise, safe and productive control.



Adjustable Steering Wheel

Steering wheel with horn button can be adjusted by a lever on the right-hand side for the most comfortable operator position.



Easy and Safe Shift Lever

A single lever on the left side of the steering column gives the operator fast, easy control of direction. The lever must be in the neutral position before the engine can be started.



Secondary Horn

Secondary Horn gives access to lights and horn.

Danger-free through high durability!

Safety and durability are priorities in design of the equipment.



Strong Overhead Guard

The safety overhead guard meets ISO 6055 regulation and protects the operator during hazardous jobs.



Parking brake

Ratchet type parking brake requires less effort the operator to set.

Highly Durable Split type Drive Axle

The planetary reduction drive axle smoothly delivers desired torque to the drive wheels.



■ Some of the photos may include optional equipment.



Large Footboard & Hand Grip

Wide "open" step offers convenience and safety when entering and exiting truck.



Expansion Bellows

The expansion bellows absorbs vibration and reduces noise generated from the exhaust system and also extends the life cycle of exhaust system.



Electrically Monitored Air Filter

Air cleaner sensor alerts the operator of a restricted air filter and allows replacement before damage.

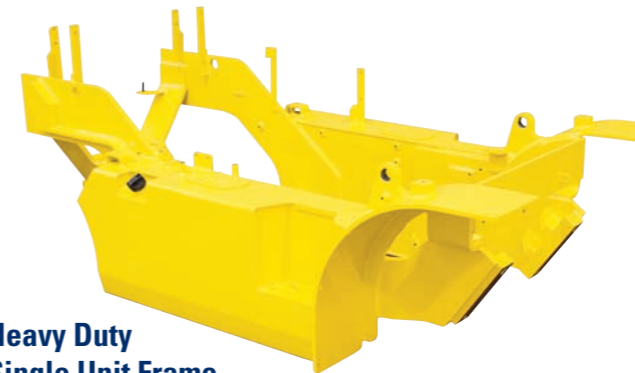

Heavy Duty Single Unit Frame

Heavy duty single unit type frame, designed on the basis of accurate structural analysis, guarantees durability and safety.



Bright, Protected Headlights

Bright, Protected head lights are positioned for exceptional visibility.

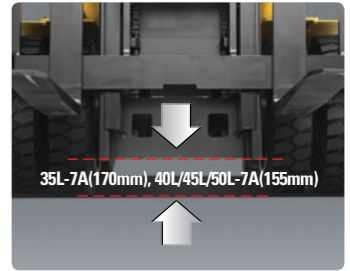

Ground Clearance

The engine and transmission are assembled horizontally and positioned high in the frame to protect major components during operation on rugged surface.

35L-7A(170mm), 40L/45L/50L-7A(155mm)

